

Explosion proof PTZ camera

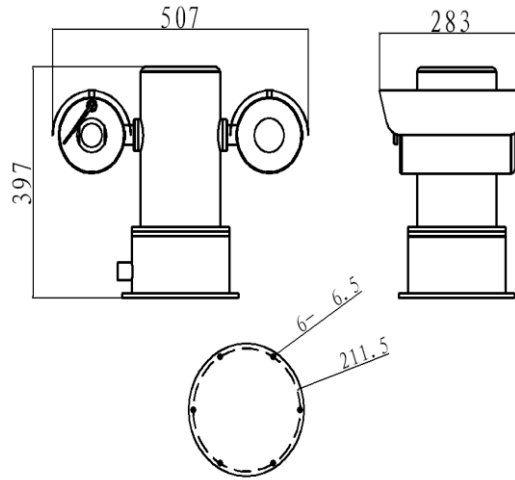

Manufacturing Standards:

GB3836.1-2000 "Electrical Equipment for Explosive Gas Atmospheres Part 1: General Requirements"

GB3836.2-2000 "Electrical Equipment for Explosive Gas Atmospheres Part 2: Flameproof Type "d""

GB 12476.1-2000 "Electrical Equipment for Combustible Dust Environments Part 1: Electrical Equipment Protected by Enclosures and Limiting Surface Temperatures"

Features:

- Highly integrated explosion-proof pan/tilt, explosion-proof infrared camera, explosion-proof decoder, smaller and lighter, more intelligent and advanced functions;
- 4.0MP high-definition integrated movement, 33X optical Zoom, 16X Digital Zoom.
- Applicable to dangerous and harsh environments where various flammable gases or dust exist, double side load structure design, can be used with auxiliary lighting equipment such as cameras and fill lights.
- Using 304 stainless steel material, integrated and simple design, the window is made of tempered glass coated with waterproof film on both sides, which is impact-resistant and has
It has good shielding and cooling effect. Explosion-proof, dust-proof, waterproof, rust-proof
- 360° horizontal rotation, -90°~+90° vertical movement, all-round monitoring of suspicious targets.
- Pelco-D/Pelco-P protocol adaptive, RS422/485 communication mode.
- RS-485 control function, compatible with various communication protocols and communication rates, can accurately and quickly respond to various host instructions;

- Optical-grade high-strength and high-transmittance ultra-white explosion-proof glass, with a luminous flux rate higher than 96%, completely eliminating the halo of infrared light;
- Semiconductor thyristor temperature control components can be selected to realize automatic heating and cooling functions.
- Work Temperature: -40°C~+60°C
- Infrared visible distance 100M IR Distance
- 304 Stainless steel / 316L Stainless steel.
- Support SD card local storage: 128GB
- Support intelligent functions of : Motion detection ,intrusion detection.

Adapt environment:

Applicable to the factory with IIA, II B, II C class T1 ~ T6 explosive mixture of flammable gas, steam and air in zone 0, 1, 2 areas and 20, 21, 20, 21, 20, 21, Area 22 is an explosion hazard area. Such as petroleum, chemical industry, wharf, oil depot, ship, drilling platform, gas station, mine, port, aerospace, military industry, medicine, steel, fireworks production, machinery, grain processing and storage and other places. The shell of this pan/tilt is made of stainless steel, and the window is made of tempered glass coated with waterproof film on both sides. It has a reasonable structure and a simple appearance. It has the functions of preset position, automatic scanning, automatic cruise, tracking, watch position and so on. It can be widely used in important fields such as border defense, military industry, warehouses, ships, and dangerous goods production.

Technical parameters

| Product model | | HL-E9002-W-4.0MP |
|---------------|-------------------------|--|
| Visible light | Imaging devices | 1/2.8 inch Scan 2 million pixels line by line CMOS image sensor |
| | Focal length/change | 33X optical Zoom, 16X Digital Zoom |
| | Zoom mode | Electric zoom, autofocus |
| | Shutter | 1/1 seconds ~1/30,000 seconds |
| | WDR | YES |
| | Minimum illumination | Color :0.001 Lux @(F1.5, AGC ON) Black and white :0.0005 Lux @(F1.5, AGCON) |
| | Day and night switching | Automatic infrared filter switching color to black |
| | Code Protocol | H.265、 H.264 |
| | Resolution | 50Hz: 25fps (2560*1440, 1920 × 1080, 1280 × 960, 1280 × 720); 60Hz: 30fps (2560*1440, 1920 × 1080, 1280 × 960, 1280 × 720) |
| | Video streaming | Three-code stream |
| | OSD | Time OSD, Custom OSD |
| | Motion detection | Support |
| | Privacy Cover | Support |

| | | | | | | |
|-----------------------------|------------------------------------|---|------------------|-----------------|-----------------|----------------|
| | Agreement | TCP/IP、HTTP、DHCP、DNS、DDNS、RTP、RTSP、PPPoE、SMTP、NTP、UPnP、SNMP、FTP、802.1x、QoS、HTTPS、IPv6(SIP、SRTP、optional)、GB28181、E-HOME | | | | |
| | Compatibility | ONVIF2.4、GB/T28181 | | | | |
| Lens | Lens type | 4.5 ~ 148.5mm, AF automatic focusing and motorized zoom lens | | | | |
| | Digital Zoom | 16 | | | | |
| | Optical Zoom | 33 | | | | |
| | Iris | Auto; F1.5 ~ F4.0 | | | | |
| | Field of View (H) | 56.2° ~ 2.6° | | | | |
| | Field of View (V) | 33.5° ~ 1.4° | | | | |
| | Field of View (D) | 69.2° ~ 3.0° | | | | |
| DORI | | Lens (mm) | Detect (m) | Observe (m) | Recognize (m) | Identify (m) |
| | DORI Distance | 4.5 | 72.9(239.3ft) | 29.2(95.7ft) | 14.6(47.9ft) | 7.3(23.9ft) |
| | | 148.5 | 2187.9(7178.3ft) | 875.2(2871.3ft) | 437.6(1435.7ft) | 218.8(717.8ft) |
| Head | Range of rotation | Horizontal 0-360° continuous rotation, vertical +90°~90° | | | | |
| | Speed of movement | Level :0.1°-30° s, vertical :0.1°-30 per cent | | | | |
| | Positioning accuracy of cloud head | ±0.1° | | | | |
| | Preset points | 255 | | | | |
| | Cruise scan | 8, each can add 32 preset points | | | | |
| | Pattern scanning | 4, each path recorded for more than 10 minutes | | | | |
| | Power off memory | Support | | | | |
| | Watch function | Support | | | | |
| | Variable Speed Limit | Support | | | | |
| | Intelligent features | Motion detection ,intrusion detection. | | | | |
| | Auto Mode | Automatic cruise or arbitrarily set two-point patrol range | | | | |
| Azimuth information display | ON/OFF | | | | | |
| General norms | Explosion proof signs | Ex d IIC T6Gb/Ex tD A21IP68T80°C | | | | |
| | Power supply mode | AC85V ~260 V/DC24V 3A(optional) | | | | |
| | Working temperature and humidity | -40°C~60°C, humidity less than 90% RH(no condensation) | | | | |
| | Protection level | IP68 | | | | |
| | Shell material | 304 stainless steel material (chemical, acid and alkali corrosive environment use) | | | | |
| | Incoming hole specification | 1 G3/4" feed hole | | | | |
| | Installation mode | A variety of installation options depending on the application environment | | | | |
| | Pressure | 80-106KPa | | | | |
| | IR Distance | 100Meters | | | | |
| Product weight | 34kgs | | | | | |