

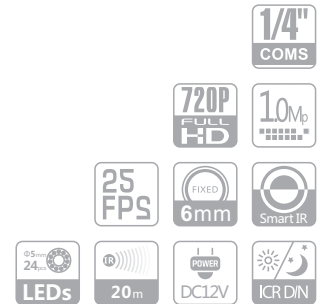

Model Number:
AX-100DA-AHD



Main Features:

- ◆ 1/4" CMOS sensor, 720P 1.0MP (1280×720)
- ◆ BNC port, transmission distance(coaxial cable 75-3 @720P) is 500m
- ◆ Support HD video
- ◆ With IR-CUT for days and night
- ◆ OSD menu(optional)
- ◆ 24pcs Φ5 LED, 20M IR, 6mm Fixed lens
- ◆ Size: D94×H73(mm), Weight: 0.5KG
- ◆ Color: white/Black

Size(mm):

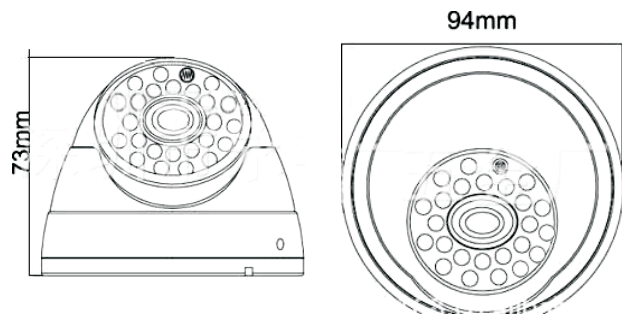

Specifications:

Camera	
Model	AX-100DA-AHD
Chip	NVP2431H ISP processor
Sensor	1/4" CMOS sensor
Effective pixels	1280×720
Video	AHD and CVBS standard
System	PAL/NTSC
Video output	1ch AHD HD/CVBS standard definition output(can switch)
Frame rate	PAL: 1280×720@25fps NTSC:1280×720@30fps
Transmission distance max	Over 500M via coaxial cable 75-3
Day&night	IR-CUT auto switch
OSD menu	Optional
White balance	Auto/manual
BLC	Off/low/middle/high/very high
HLC	Support

Camera Features	
IR LEDs Length	20-25m IR
Day/Night	Auto(ICR)/Color/B/W

Lens

Focal Length | 6mm Fixed lens

General

Power Supply	DC12V 1A
Consumption	4W±10%
Working Environment	-20°C~+55°C/ Humidity 95% or less (non-condensing)
Transmission Distance	Over 500m via 75-3 coaxial cable
Material	Plastic
Dimensions	D94×H73(mm)
Weight	0.5 KG

Note:

- ◆ Do not use clothes or any ordinary material to clean the camera cover since they may result in scratches.
- ◆ Specifications are subject to change without notice.

Packing List:

- ◆ Dome Camera
- ◆ Accessories screws
- ◆ Software CD
- ◆ Sticker

Specifications are subject to change without notice.

ANSON (HK) Technology Company Limited

Shenzhen Enerson Technology Company Limited

Headquarter
Address: 4F, Block 5, Wuzi Industrial Park, Fada Road, Bantian,
Longgang District, Shenzhen, China

Tel: +86-755-28188843
Fax: +86-755-28188834
Mail: info@cctv-ax.net
Http: www.cctv-ax.com

